

Product Change Notice (PCN)

Date: 4/19/2023

PCN Number: **PCN-0450031R-01**

To Our Customers:

We appreciate your use of our products. Our commitment in maintaining and improving processes is demonstrated by plans to enhance our product quality, reliability, and manufacturability. The purpose of this notice is to inform you of a product change.

Product(s) Affected: PJ-080BH

Reason(s) for Change: *Manufacturing process improvements*

Description of Change: mechanical, material, soldering, and packaging differences as shown below:

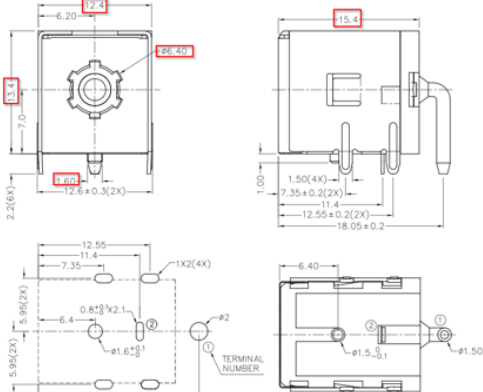
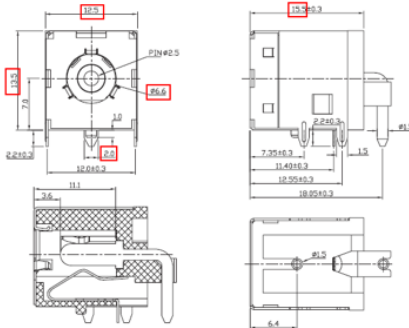
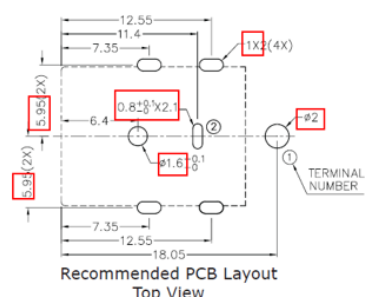
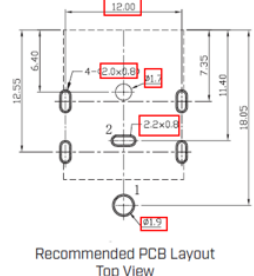
PREVIOUS CUI DEVICES DETAIL / IMAGE	NEW CUI DEVICES DETAIL / IMAGE
	
 <p>Recommended PCB Layout Top View</p>	 <p>Recommended PCB Layout Top View</p>

	MATERIAL	PLATING
terminal 1	brass	silver
terminal 2	copper alloy	silver
stopper	cold rolled steel	nickel
shield A	cold rolled steel	nickel
shield B	stainless steel	
plastic	PA6T or equivalent	

DESCRIPTION	MATERIAL	PLATING/COLOR
center pin	brass	nickel
terminal 1	brass	nickel
terminal 2	bronze	nickel
shield	brass	nickel
housing	PA9T (UL94V-0)	black

parameter	conditions/description	min	typ	max	units
wave soldering	dipped in solder pot for 5 ±0.5 seconds at	255	260	265	°C
reflow soldering ¹	at relative humidity <80%			40	°C
reflow soldering ²	see reflow profile	255	260	265	°C
drying conditions ³	parts in reel: bake at 40°C ±5°C for 72 hours parts removed from reel: bake at 40°C ±5°C for 10 hours				

Note: 1. Must reflow solder within 72 hours from opening vacuum packaging at a temperature <30°C & relative humidity <60%.
2. When exceeding floor life by >72 hours.

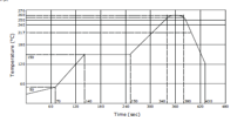

parameter	conditions/description	min	typ	max	units
reflow soldering	reel covered & unused parts repacked within 2 hours: <30°C, <60% humidity reel unopened, 1 year shelf life: <30°C, <65% humidity			260	°C
reflow soldering	see reflow profile				
drying conditions	parts removed from reel over 6 hours: bake at 40°C for 6 hours				

Note: 1. Cu Devices recommends usage of the product within 2 hours after TSM is opened. After 6 hours, Cu Devices recommends drying the parts prior to use.

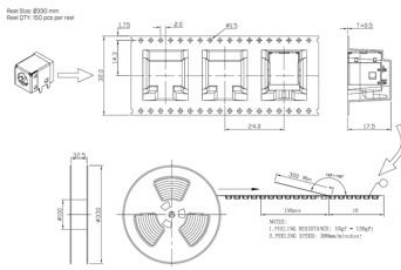
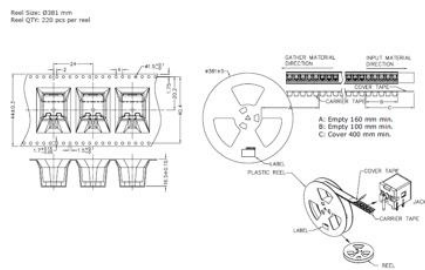
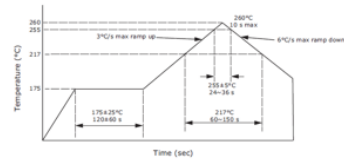

Affected Date Code: 4/19/23

Product Availability: Channel Availability Q2

Additional Information:

PCN Approval:

Operations/Quality

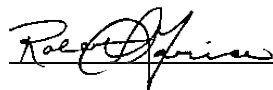

Product Management



F-723-001

Revision: A